

**SHORELINE COMMUNITY COLLEGE  
BOARD OF TRUSTEES SPECIAL MEETING OF SEPTEMBER 27, 2023**

4:30 PM – Board Room (#1010M), Bldg. 1000

**Remote Option via Zoom:** <https://us02web.zoom.us/j/88349708605> -or-  
(253) 215-8782 ▪ Meeting ID: 883 4970 8605

**AGENDA**

| <b>4:30 PM</b>    |   |   |                   |
|-------------------|---|---|-------------------|
| <b><u>No.</u></b> | <b><u>Agenda Item</u></b>   | <b><u>Responsibility</u></b>  | <b><u>Tab</u></b> |
| 1.                | <b>Convene Special Meeting &amp; Land Acknowledgement</b>   | <i>Chair Rebecca Chan</i>   |                   |
| 2.                | <p><b>Communication from the Public</b></p> <p>-<u>For attendees attending in-person</u>: Please sign-up to provide a public comment on the speaker sign-in sheet in the Board Room (#1010M) between 4:15 PM–4:30 PM on September 27, 2023.</p> <p>-<u>For attendees connecting online</u>: Please sign up to provide a public comment via the Chat function in Zoom between 4:15 PM–4:30 PM on September 27, 2023.</p> <p>The Board Chair will call upon each speaker signed up to provide public comment. The total public comment period at the September 27, 2023 meeting will be no more than ten (10) minutes with up to two (2) minutes allotted per speaker. Adjustments to the two (2) minute allotment will be made if more than five (5) individuals sign up to speak. (For the entering of a public comment into the record and attaching to the minutes of the September 27, 2023 meeting, please send written public comment to Board Secretary Lori Yonemitsu at <a href="mailto:lyonemitsu@shoreline.edu">lyonemitsu@shoreline.edu</a> following the September 27, 2023 meeting.)</p> | <i>Chair Rebecca Chan</i>   |                   |
| 3.                | <b>Action: Buildings Naming Proposal</b>  | <i>Jack Kahn, President,<br/>Wendy Coates,<br/>Executive Director &amp;<br/>Aisha Hauser, Acting<br/>Vice President</i> | <b>1</b>          |
| 4.                | <b>Action: 2023-2024 College Operating Budget</b>   | <i>Jack Kahn, President &amp;<br/>Becca Chen, Budget<br/>Consultant</i>   | <b>2</b>          |
| 5.                | <b>Action: Resolution No. 168—Commending Service of Trustee Tom Lux</b>   | <i>Chair Rebecca Chan</i>   | <b>3</b>          |
| 6.                | <b>Action: Adjournment</b>  | <i>Chair Rebecca Chan</i>   |                   |

Next regular meeting of the Board of Trustees: Wednesday, October 25, 2023

**SHORELINE COMMUNITY COLLEGE  
DISTRICT NUMBER SEVEN  
BOARD OF TRUSTEES  
SPECIAL MEETING OF SEPTEMBER 27, 2023**

**TAB 1**

**ACTION**

**Subject: Buildings Naming Proposal**

**Background**

Per Shoreline Community College [Policy 3802 \(Naming of Facilities\)](#), the Board of Trustees approves all recommendations for naming of buildings. A \$1.5 million donation was made by the Associated Student Government (ASG) Sustainability and Commuter Options Fee to the Health Sciences and Advanced Manufacturing Classroom Complex (HSAMCC) building. Following that, a subgroup of ASG students, faculty, staff and members of our indigenous community have been working on a proposal consonant with the ASG wishes as well as the College's dedication to improving our work with our Government-to-Government tribal partners.

The team proposed a naming scheme consisting of a list of several indigenous trees to use to name buildings across campus, beginning with "HSAMCC" to be named "Cedar." Elise Bill-Gerrish, a member of the Muckleshoot Indian Tribe, converted the list into Lushootseed and provided digital files of the pronunciations to be featured via QR code in signage in the building.

**To follow:**

- SCC\_Exec Committee Bldg Naming Presentation - 23-0925

**Recommendation**

That the Board of Trustees, by motion and subsequent action, approve the recommendation to name the (HSAMCC Building ID) CEDAR ʔəpəyʔac and to use this naming scheme (described above) for the "Stem" building and other existing buildings (as appropriate with feedback from the college community).

Prepared by: Jack Kahn – President  
Wendy Coates – Executive Director, Foundation & Advancement  
Aisha Hauser – Acting Vice President, Diversity, Equity, Inclusion, Accessibility  
Shoreline Community College  
September 26, 2023

## ORGANIZING PRINCIPLES

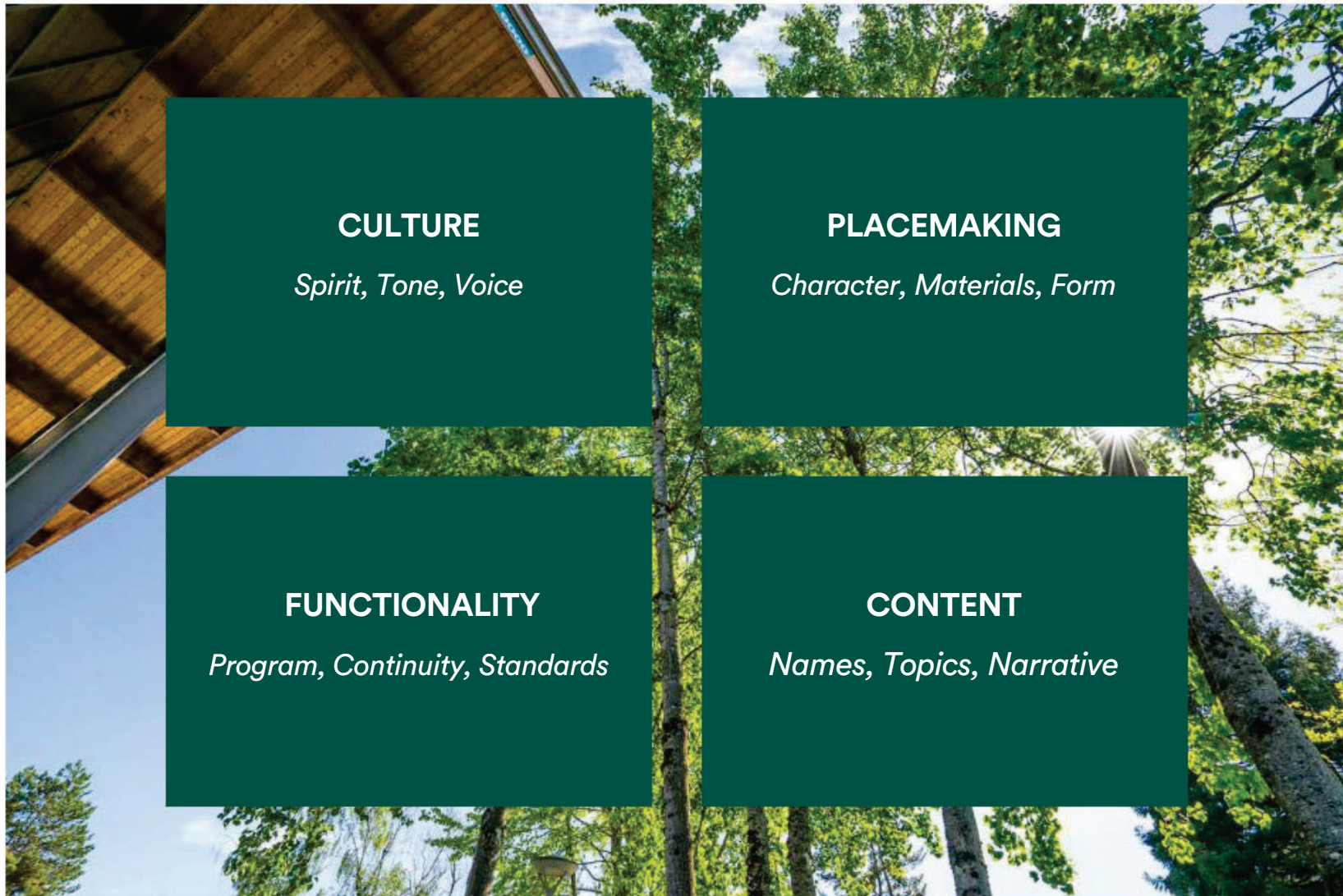

## CAMPUS SITE FRAMEWORK PLAN

### CULTURE

- Bringing Together & Inspiring
- Acknowledging Past/Present
- Celebrating Students
- Belonging
- Forward-Looking

### PLACEMAKING

Open Areas, Circulation, Landscape, Pathways, Buildings, Wayfinding, Artwork, Features, Interpretives, Touchpoints, Gathering

### NAMING

- Core Areas
- Main Pathways
- All Buildings

### DESIGN

- Experiential Features
- Continuity & Functionality
- Connected Spaces
- Campus Character

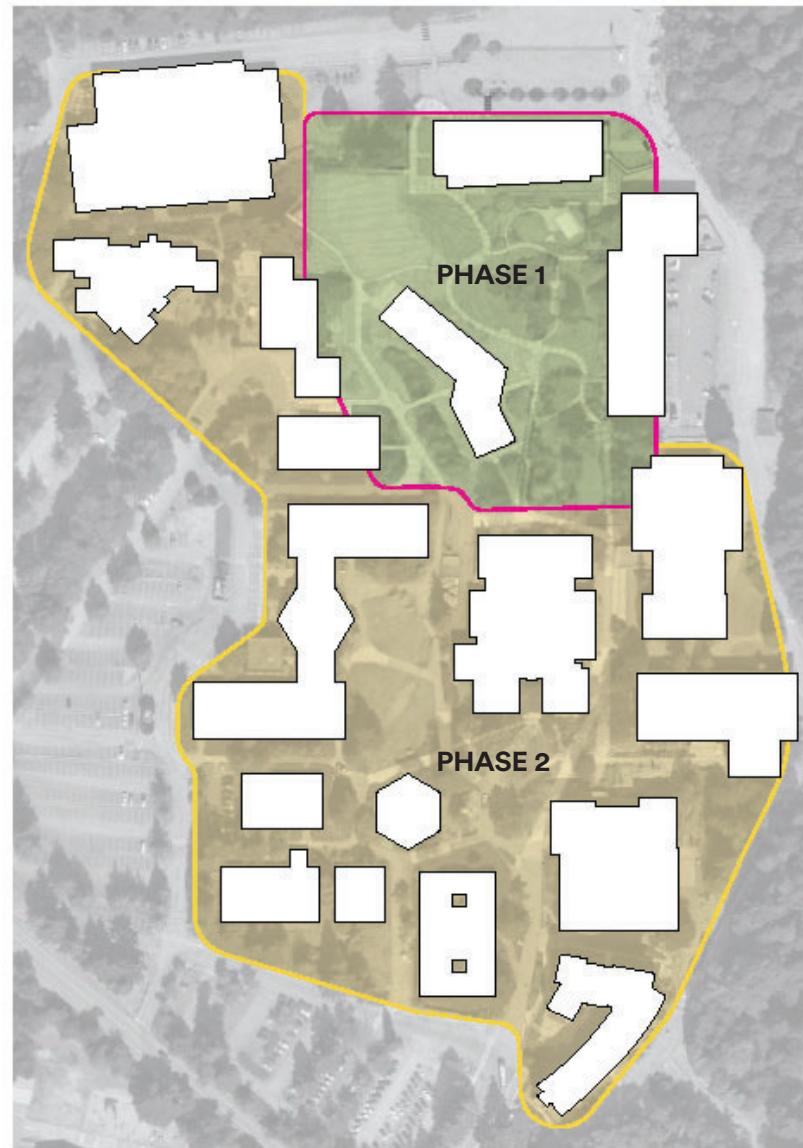

# NAMING TYPOLOGY

## CORE AREAS - Landscape and Plazas



## MAIN PATHWAYS - Circulation and Wayfinding



## BUILDING NAMES - Destinations and Programs

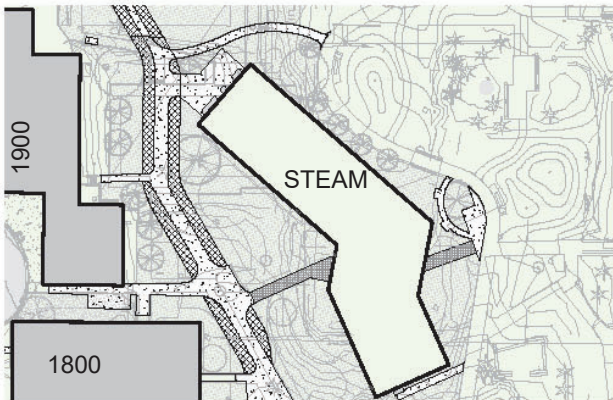

## CORE AREAS

**RMBVivid**



### CAMPUS CONTINUITY

- Entrance and Orientation (you are here)
- Destination Wayfinding (placenames)
- Narrative Touchpoints (i.e. timeline)
- Sense of Place (identity/culture)
- Common Design Language (standards)



# CAMPUS SITE FRAMEWORK PLAN

## BUILDINGS

- Name ID Standard (ext. name/font)
- Name Design Standard (ext. material, mounting)
- Name Location Standard (ext. entries, approach)
- Fire Dept. (ext. bldg. numbers)
- Building Interior Directory (interior map)
- Code Signage Standard (int. style, material, mounting)

## CAMPUS MAP

- Village, Meadow, Forest (zones)
- River (main path), Creeks (pathways)
- Proper Names (buildings)
- Access Points/Routes (parking,transit, ADA, bike)
- Orientation Nodes (1 per zone)

## WAYFINDING

- Orientation and Directionals (destinations, distance)
- Campus Identity (look, tone, material)
- Typology (orientation, directional, pagentry)
- Locations (zones, pathways, gathering, access)
- Design Standards (style, material, system)

## INTERPRETIVE

- Exterior Integrated (combined w/wayfinding)
- Exterior Stand-alone (landscape, seating, light poles)
- Interior Stand-alone (lobbies, open stair, areas)

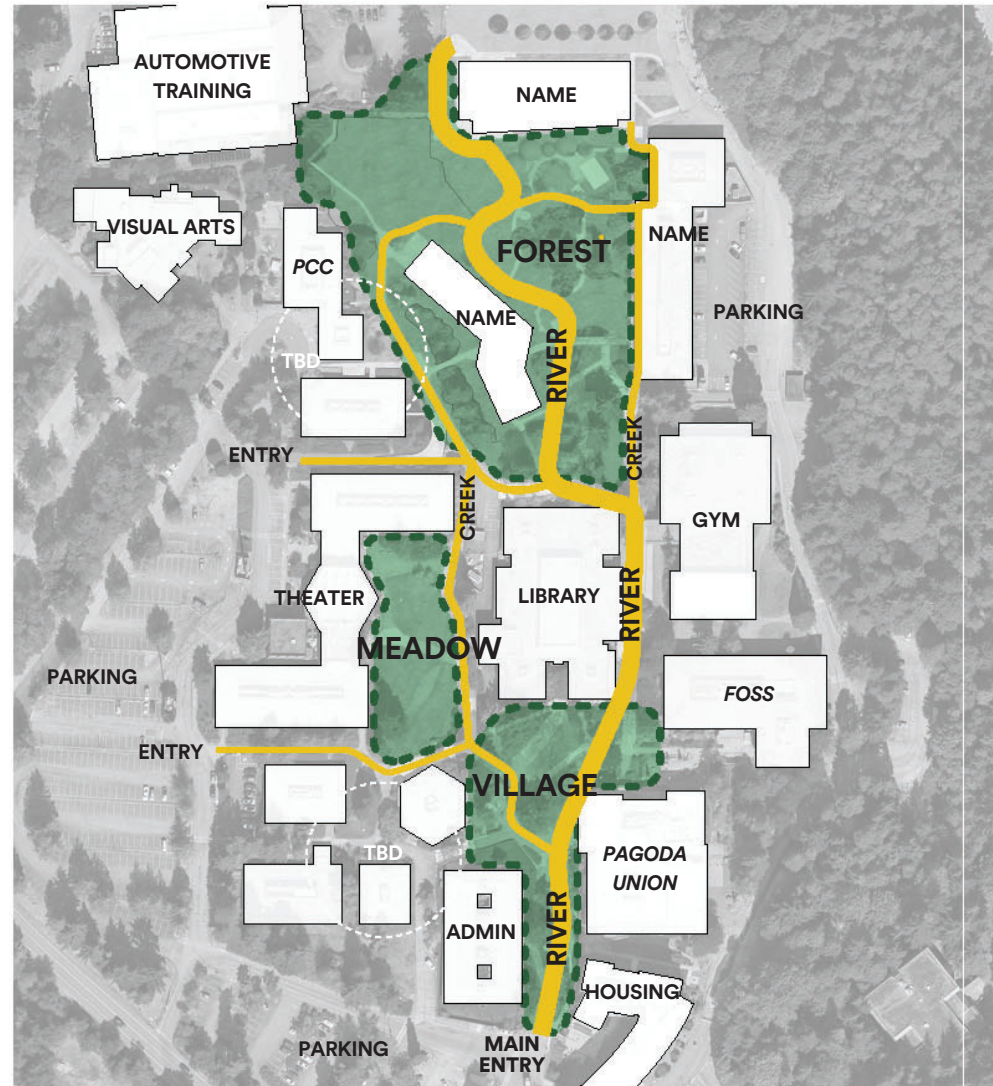

# CAMPUS SITE WAYFINDING

## Functional

- 📍 Orientation/Map
- ➕ Wayfinding Directionals
- ♿ ADA Access/ Emergency
- ★ Building Name

## Interpretive

- ▲ Land Acknowledgement
- DAHP Imagery/Narrative
- 🌿 Landscape/Green Education

## Site Improvements

- 👉 Main Pathway
- 🌿 Landscape
- 💡 Lightpoles
- 🪑 Seating
- 🎨 Artwork

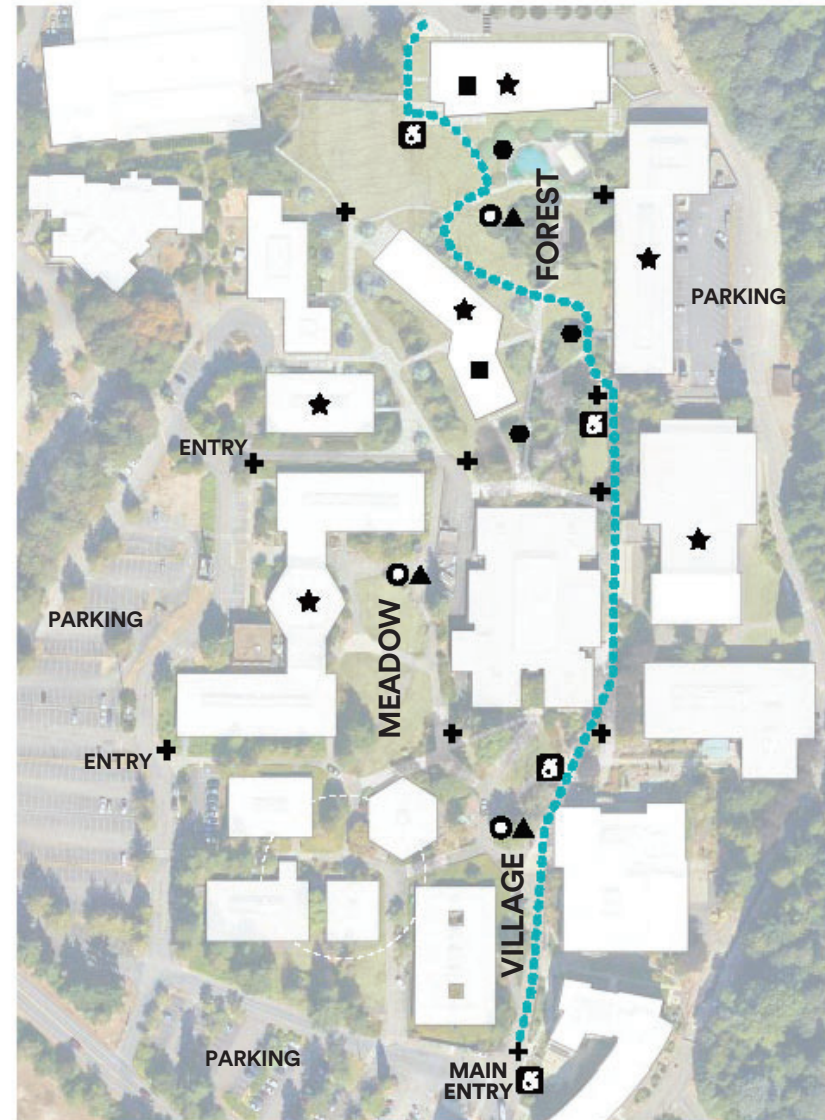



# CAMPUS IDENTITY

**RMBVivid**



**DESIGN** - style, materials, voice, content, landscape, buildings, flow

## CULTURE

- Bringing Together & Inspiring
- Acknowledging Past/Present
- Celebrating Students
- Belonging
- Forward-Looking



# CAMPUS SITE - BUILDING NAMES

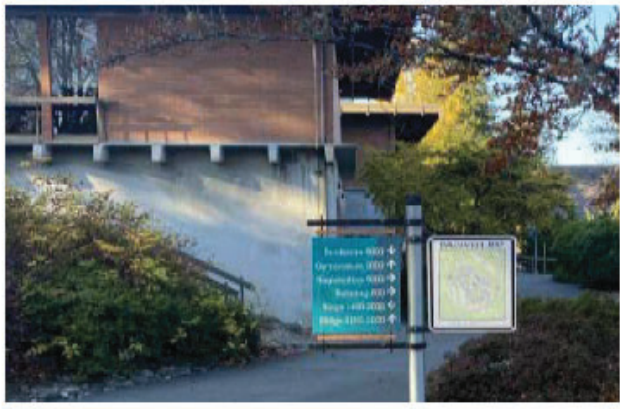
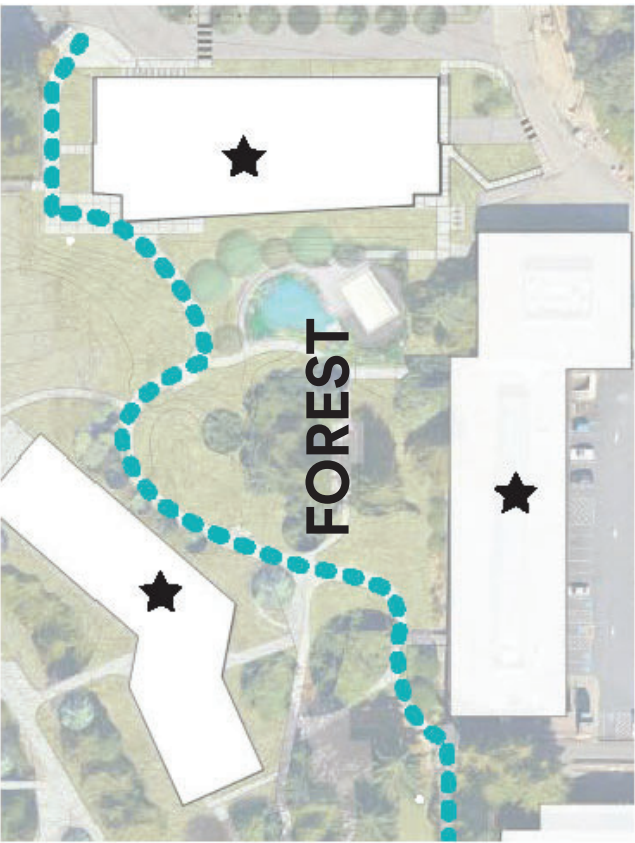

★ *Building Name*

SCALE: 3" = 1'-0"

# FOREST



BUILDING DIRECTORY  
EMERGENCY DIAL 911  
CAMPUS SECURITY 206-235-5860



SMALLEST TYPE  
3/16" CAP HEIGHT



**RMB Vivid**

1932 1st Ave. #606  
Seattle, WA 98101  
Contact: Brian Boram  
Tel: 206 956-0638  
Email: brian@rmbvivid.com

**MITHUN**

Pier 56, 1201 Alaskan Way, #200  
Seattle, WA 98101  
206.623.3344

Contact: Lowell Day  
lowelld@mithun.com  
206.971.5677

**Shoreline Community College  
HSAMCC**  
16101 Greenwood Ave N  
Shoreline, WA 98133

Job No: 180700

**Signage and  
Environmental Graphics**  
Design Set

**Sign Types**  
Master

**Date**  
2023-09-22

This is an original unpublished design document created by RMB Vivid, submitted for your review. This document and its contents are property of RMB Vivid until released, and its contents shall not be reproduced, copied, photographed, exhibited or used in any fashion without the expressed written approval of RMB Vivid.

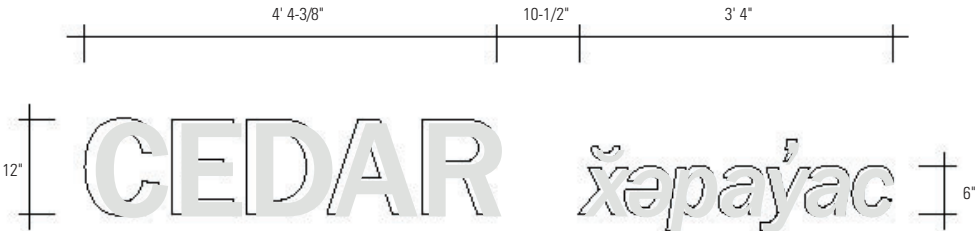

**1** HSAMCC BUILDING ID  
Scale: 3/4" = 1'-0"

 RANDOM DA BRUSHED  
NATURAL STAINLESS STEEL

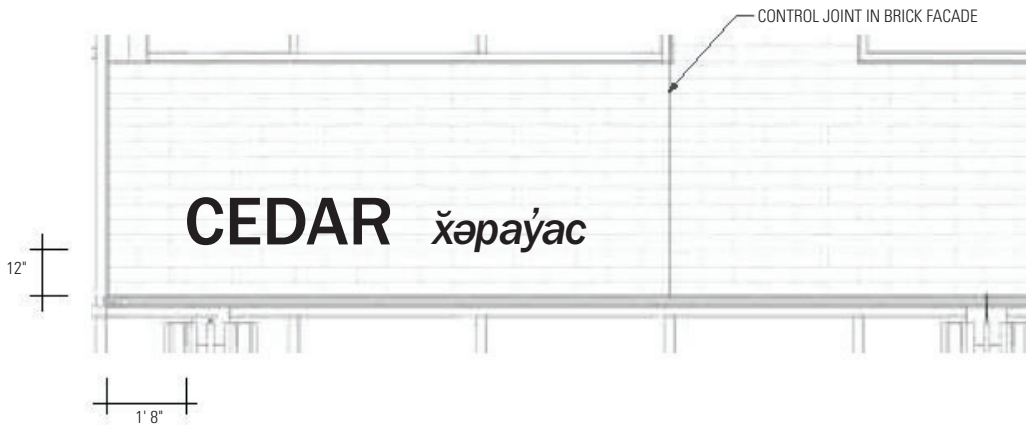
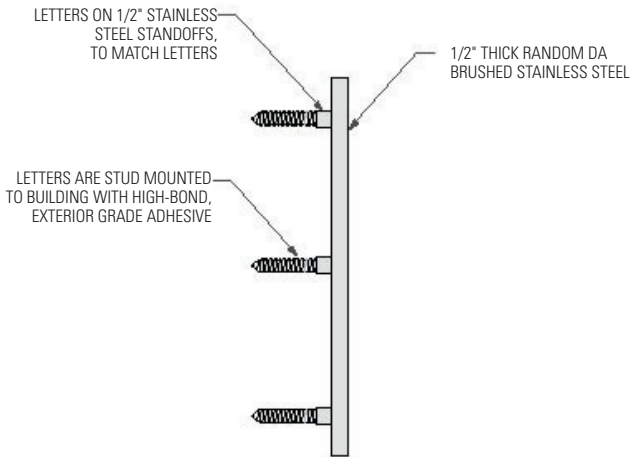

**2** HSAMCC BUILDING ID - TYP  
Scale: 3" = 1'-0"

**3** HSAMCC BUILDING ID - INSTALLATION  
Scale: 3/8" = 1'-0"

**RMBVivid**

1932 1st Ave. #606  
Seattle, WA 98101  
Contact: Brian Boram  
Tel: 206 956-0688  
Email: brian@rmbvivid.com

**MITHŪN**

Pier 56, 1201 Alaskan Way, #200  
Seattle, WA 98101  
206.623.3344  
Contact: Lowell Day  
lowelld@mithun.com  
206.971.5677

**Shoreline Community College  
HSAMCC**  
16101 Greenwood Ave N  
Shoreline, WA 98133

Job No: 180700

**Signage and  
Environmental Graphics**  
Design Set

**Sign Types**  
Master

**Date**  
2023-09-22

This is an original unpublished design document created by RMB Vivid, submitted for your review. This document and its contents are property of RMB Vivid until released, and its contents shall not be reproduced, copied, photographed, exhibited or used in any fashion without the expressed written approval of RMB Vivid.



**Requested Names:**

- Cedar
- Madronn
- Alder
- Cascara
- Birch
- Wapato
- Camas
- Bracken Fern

| ENGLISH         | baqłšutucid (The Muckleshoot Language) |
|-----------------|--|
| CEDAR TREE      | ḵapayac                                |
| ALDER TREE      | yosawi                                 |
| CASCARA         | ḵacabac                                |
| CAMAS ROOT      | ḵabid                                  |
| BRACKEN FERN    | ḵalac                                  |
| WILLOW TREE     | scapac                                 |
| HAWTHORN TREE   | ḵabidac                                |
| NETTLE          | scad'x                                 |
| COTTONWOOD TREE | q'adl7q'ac                             |
| MAPLE TREE      | cu7lac                                 |

**1** HSAMCC BUILDING ID  
Scale: 1/8" = 1'-0"









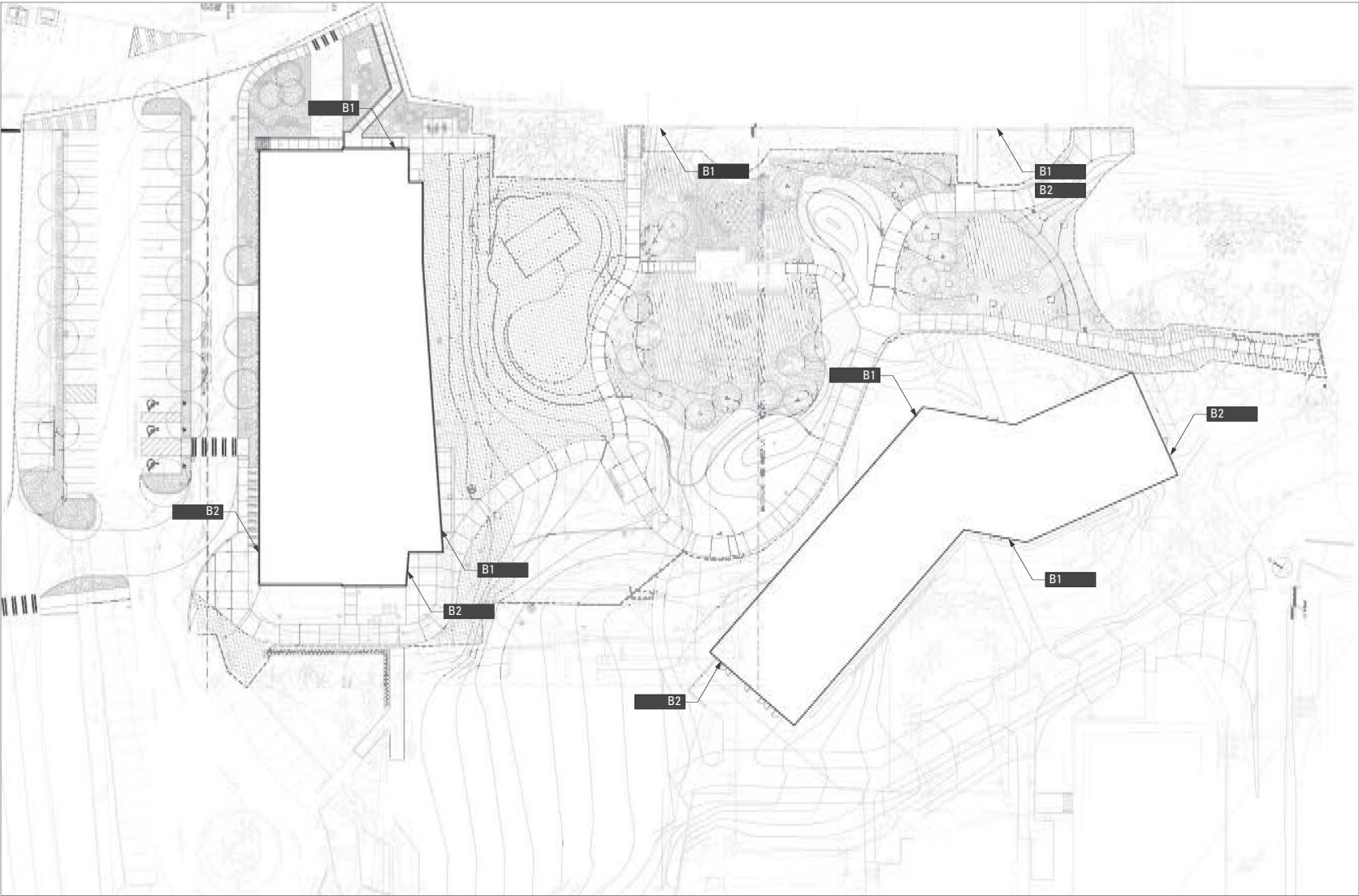

SCALE: 1" = 30'-0"

**SHORELINE COMMUNITY COLLEGE  
DISTRICT NUMBER SEVEN  
BOARD OF TRUSTEES  
SPECIAL MEETING OF SEPTEMBER 27, 2023**

**TAB 2**

**ACTION**

**Subject: 2023-2024 College Operating Budget**

**Background**

The College’s most recent budgeted year (FY 2022-2023) ended on June 30, 2022, which is directly aligned with the fiscal year of the State of Washington. To establish proper spending authority for the institution, it is necessary for the College to adopt a budget for the current fiscal year (FY 2023-2024), which began on July 1, 2023.

At its regular meeting of April 26, 2023, the Board of Trustees approved Resolution No. 166 (Authorizing Continuing Operations of Shoreline Community College), commencing July 1, 2023, and in effect through September 30, 2023 which “authorized the continued operation of the District under the full delegations of authority to the President. Such authority includes the authority to expend available State, Tuition, Local, Contract, and Grant funds to fully operate the District in accordance with established practices.”

The total estimated operating expenditure is recommended to be \$53,881,617 for FY 2023-2024.

These expenditures would be funded from the budgeted revenue sources of:

|   |                     |
|---|---------------------|
| State Allocation  | \$37,722,364        |
| Tuition and major contract revenues<br>(Domestic, International, Running Start, CECO) | \$16,159,253        |
| The total Estimated operating budget<br>for FY2023-2024                               | <u>\$53,881,617</u> |

**Recommendation**

That the Board of Trustees, by motion and subsequent action, approve the Operating Budget as presented for Fiscal Year 2023-2024 in the amount of \$53,881,617; FURTHER MOVED, That the College President may adjust the operating budget up or down by up to one (1) percent of estimated operating revenues.

Prepared by: Jack Kahn – President  
Becca Chen – Budget Consultant  
Shoreline Community College  
September 26, 2023

**SHORELINE COMMUNITY COLLEGE  
DISTRICT NUMBER SEVEN  
BOARD OF TRUSTEES  
SPECIAL MEETING OF SEPTEMBER 27, 2023**

**TAB 3**

**ACTION**

**Subject: Board Resolution No. 168  
(Commending Service of Trustee Tom Lux)**

---

**Resolution No. 168  
Commending Service of Trustee Tom Lux**

WHEREAS, Trustee Tom Lux has served Shoreline Community College as a member of the Board of Trustees from 2013; and

WHEREAS, Trustee Lux has worked diligently and tirelessly on behalf of all students and their families—establishing stronger connections between the College and the communities it serves; and

WHEREAS, Trustee Lux has provided outstanding leadership to the Board; and

WHEREAS, his wisdom, advocacy and experiences have brought strength and commitment to the Board; and,

NOW, THEREFORE, BE IT RESOLVED by the Board of Trustees of Shoreline Community College to publicly proclaim its appreciation to Trustee Lux for his extraordinary service to the community, students, staff, and trustees; and,

BE IT FURTHER RESOLVED that the Board wishes Trustee Lux every success as he continues to serve the community-at-large and stays connected to the College.

The Board hereby adopts Resolution No. 168.

Done in Open Public Meeting by the Board of Trustees this 27<sup>th</sup> Day of September 2023.

Board of Trustees  
Shoreline Community College  
District Number Seven

By: \_\_\_\_\_  
Rebecca Chan, Chair

---

**Recommendation**

That the Board of Trustees, by motion and subsequent action, approve Resolution No. 168 (Commending Service of Trustee Tom Lux).

Prepared by: Lori Yonemitsu  
Executive Assistant to the President  
Shoreline Community College  
September 26, 2023